

QEP, IRB, FERPA, and SACS-COC: Meeting all the standards and regulations

- ▶ Dan Ratliff, PhD
St. Mary's University, San Antonio, Texas
- ▶ James Baker, PhD
University of the Incarnate Word, San Antonio, Texas



Universities are using greater rigor to meet SACS-COC standards for meaningful and valid outcomes assessment. As the rigor of assessment increases, federal IRB standards for protection of human subjects in research may become relevant.

- ▶ SACS COC Comprehensive Standards:
 - ▶ 3.3 Institutional Effectiveness
 - ▶ 3.3.1 The institution identifies expected outcomes, assesses the extent to which it achieves these outcomes, and provides evidence of improvement based on analysis of the results in each of the following areas:
 - ▶ 3.3.1.1 educational programs, to include student learning outcomes
 - ▶ 3.3.1.2 administrative support services
 - ▶ 3.3.1.3 academic and student support services
 - ▶ 3.3.1.4 research within its mission, if appropriate
 - ▶ 3.3.1.5 community/public service within its mission, if appropriate

How does HHS view quality improvement activities in relation to the regulations for human research subject protections?

Does the activity involve research? 45 CFR 46.102(d)

Research means a systematic investigation, including research development, testing and evaluation, designed to develop or contribute to generalizable knowledge. Activities which meet this definition constitute research for purposes of this policy, whether or not they are conducted or supported under a program which is considered research for other purposes. For example, some demonstration and service programs may include research activities.

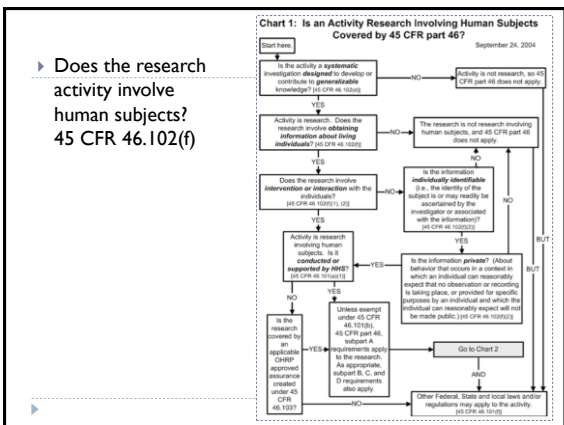

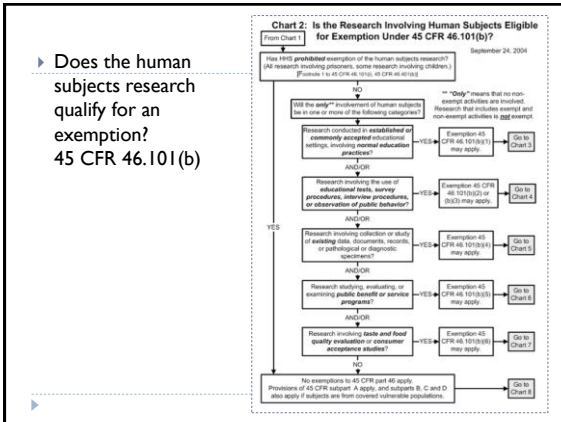

Does the human subjects research qualify for an exemption? 45 CFR 46.101(b)

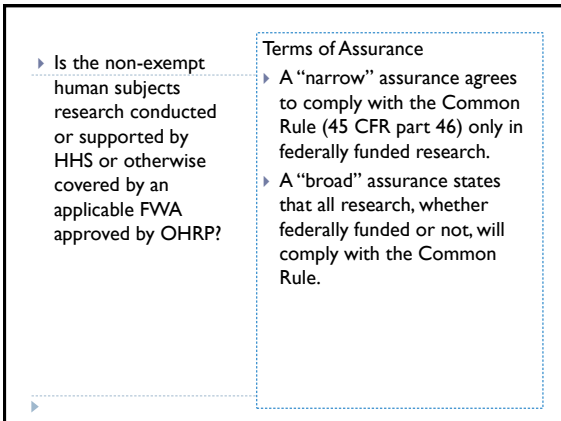

Example: Blanket IRB Proposal

How do FERPA Guidelines for student privacy protocols impact quality improvement?

▶ What is an “educational record”?

FERPA defines education records as information:

- ▶ Directly related to a student, specifically any information recorded in any way, including but not limited to handwriting, print, computer media, videotape or audiotape, film, microfilm, and microfiche; and
- ▶ Maintained by an education agency or institution, or by parties acting for the agency or institution (e.g., special education schools and health or social services institutions).

▶ Under what conditions is prior consent not required to disclose information (specific to QEP)?
34 CFR 99.31

Prior consent is not required if the information is:

1. Distributed to other institution officials, including teachers who have been determined to have legitimate educational interests;
2. Distributed to an accrediting organizations to carry out their accrediting functions;
3. De-identified—contains no information that could disclose the identity of the student.

▶ **Legitimate educational interests**
34 CFR 99.31 (I)(i)(A)

The National Center for Education Statistics notes that, while FERPA does not define "legitimate educational interests," institutions are required to have their own definitions that are distributed in annual FERPA notification letters to parents. For guidelines, see https://nces.ed.gov/pubs2004/pri_vacy/section_4b.asp

▶ **Not defined by FERPA**

▶ **Relevance:**

- ▶ Applies to execution of quality enhancement programs on the institution level.
- ▶ Supports the process of collecting and sharing student data among institutional personnel who are involved in the execution of a QEP for accreditation purposes.
- ▶ Does NOT allow for disclosing any identifiable student information outside of the institution personnel involved in study.

▶ **Is the data being distributed to an accrediting organization to carry out their accrediting function?**
34 CFR 99.31 (a)7

▶ **Directly grants consent for quality improvement programs**

▶ **Does NOT permit disclosing any identifiable student information outside of the institution personnel involved in study and the accrediting organization.**

▶ **Data de-identified**
34 CFR 99.31 (b)

▶ **Removal of all personally identifiable information**

▶ **Reasonable determination that a student's identity is not personally identifiable, whether through single or multiple releases, and taking into account other reasonably available information**

▶ **Allows for record coding**

- ▶ Code does not allow a recipient to identify a student
- ▶ Code used only used for education research and not to determine the identity of the student
- ▶ Code is not based on the student's SSN or other personal information.

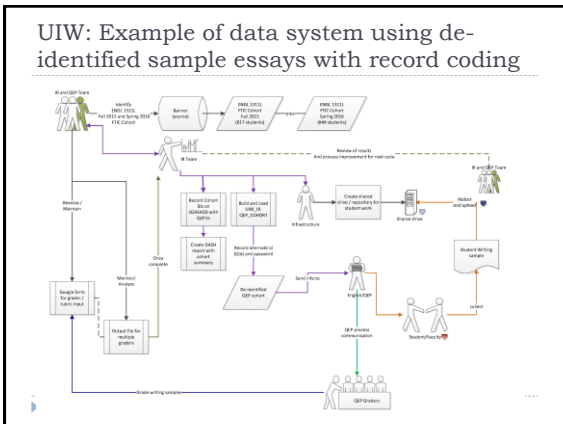

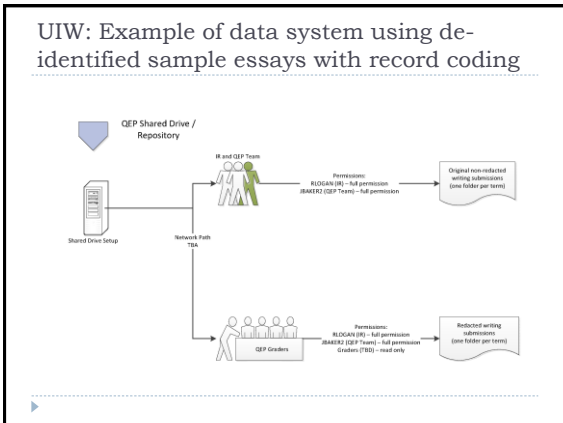

- ▶ Obtain consent form for any public use of data that does not meet the criteria for non-consent 34 CFR 99.30
- ▶ Student (and/or the parent if the student has been claimed as a dependent for tax purposes).
- ▶ The consent form must:
 - ▶ Be a dated with a written signature;
 - ▶ Specify the records to be disclosed;
 - ▶ State the purpose of the disclosure;
 - ▶ Identify to whom the disclosure may be made.

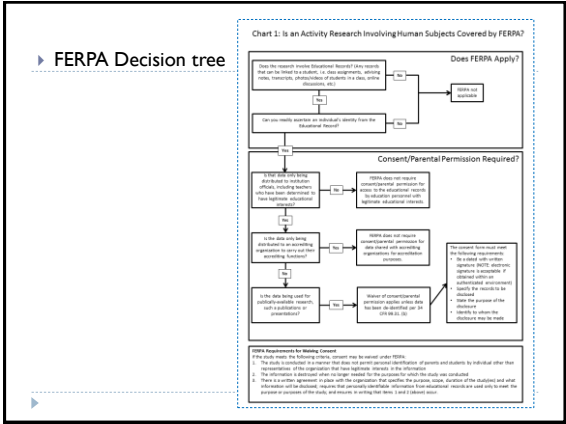

Scenario Activity 1

Scenario Activity 2

Best Practices

- ▶ Consult your local IRB for guidance regarding institution-specific policy
- ▶ Consider a system for de-identifying student data

▶

Guidance from the Office of Human Research Protection:

How does HHS view quality improvement activities in relation to the regulations for human research subject protections?

<http://www.hhs.gov/ohrp/policy/faq/quality-improvement-activities/view-quality-improvement-activities.html>

Protecting human subjects during research activities is critical and has been at the forefront of HHS activities for decades. In addition, HHS is committed to taking every appropriate opportunity to measure and improve the quality of care for patients. These two important goals typically do not intersect, since most quality improvement efforts are not research subject to the HHS protection of human subjects regulations. However, in some cases quality improvement activities are designed to accomplish a research purpose as well as the purpose of improving the quality of care, and in these cases the regulations for the protection of subjects in research (45 CFR part 46) may apply.

To determine whether these regulations apply to a particular quality improvement activity, the following questions should be addressed in order:

1. **does the activity involve *research* ([45 CFR 46.102\(d\)](#));**
2. **does the research activity involve human subjects ([45 CFR 46.102\(f\)](#));**
3. **does the human subjects research qualify for an exemption ([45 CFR 46.101\(b\)](#)); and**
4. **is the non-exempt human subjects research conducted or supported by HHS or otherwise covered by an applicable FWA approved by OHRP.**

For those quality improvement activities that are subject to these regulations, the regulations provide great flexibility in how the regulated community can comply. Other laws or regulations may apply to quality improvement activities independent of whether the HHS regulations for the protection of human subjects in research apply.

1. Does the activity involve *research* ([45 CFR 46.102\(d\)](#));

§46.102 Definitions.

(d) *Research* means a systematic investigation, including research development, testing and evaluation, designed to develop or contribute to generalizable knowledge. Activities which meet this definition constitute research for purposes of this policy, whether or not they are conducted or supported under a program which

is considered research for other purposes. For example, some demonstration and service programs may include research activities.

2. Does the research activity involve human subjects ([45 CFR 46.102\(f\)](#));

Chart 1: Is an Activity Research Involving Human Subjects Covered by 45 CFR part 46?

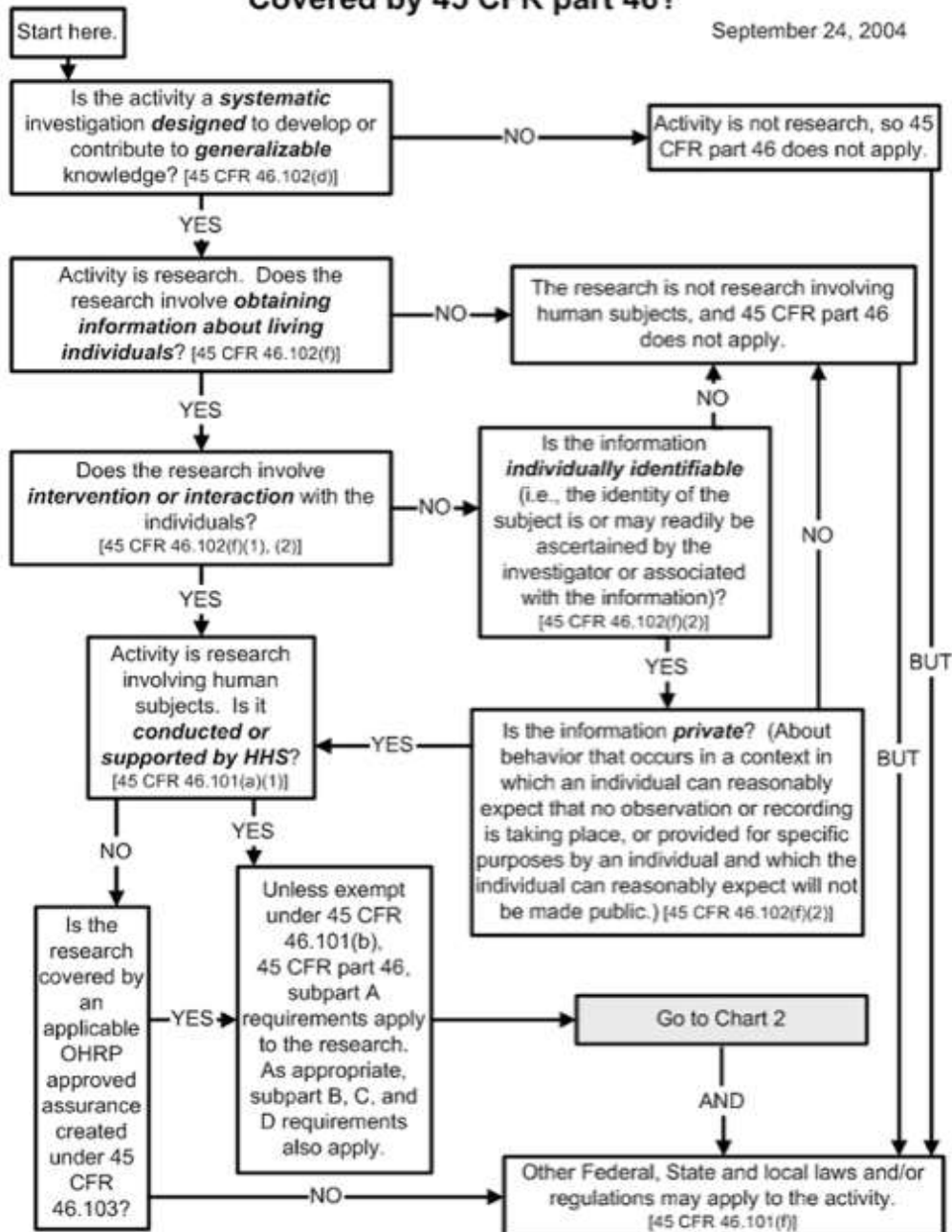

3. Does the human subjects research qualify for an exemption ([45 CFR 46.101\(b\)](#));

The determination about whether a study is exempt is made by the Institutional Review Board for Protection of Human Subjects to avoid conflict of interests.

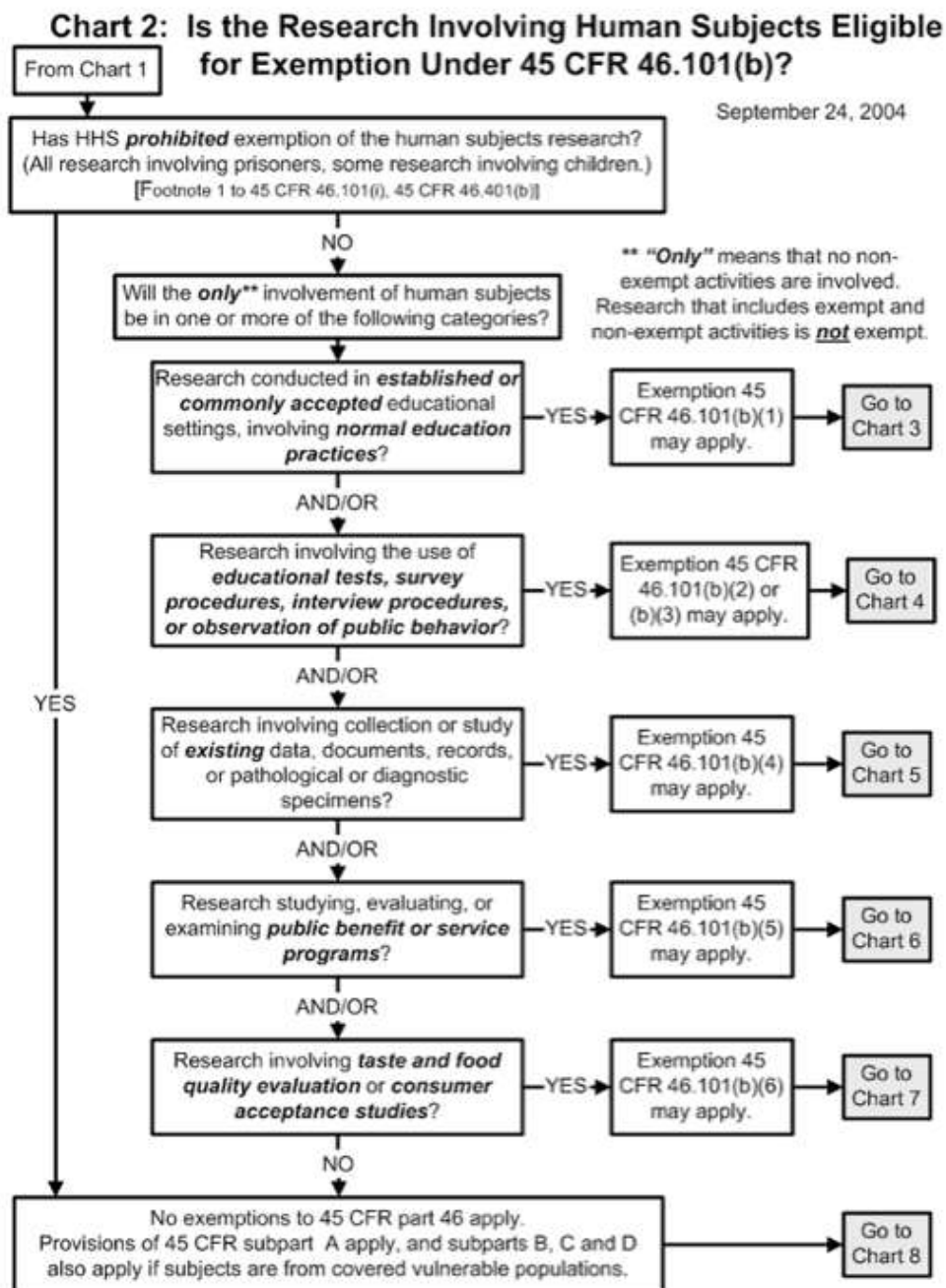

4. Is the non-exempt human subjects research conducted or supported by HHS or otherwise covered by an applicable FWA approved by OHRP.

Under the Federal Wide Assurance (FWA), an institution commits to HHS that it will comply with the requirements set forth in [45 CFR part 46](#), as well as the [Terms of Assurance](#).

Each institution may agree to “narrow” or “broad” terms of assurance. A “narrow” assurance agrees to comply with the Common Rule (45 CFR part 46) only in federally funded research. A “broad” assurance states that all research, whether federally funded or not, will comply with the Common Rule.

How do FERPA Guidelines for student privacy protocols impact quality improvement?

The FERPA statute is found at [20 U.S.C. § 1232g](#) and the FERPA regulations are found at [34 CFR Part 99](#).

The Family Educational and Privacy Act (FERPA or the Buckley Amendment) codifies regulations that apply to the protection of student educational data¹. FERPA grants access of educational records to parents of students, the right for parents to request for records to be amended, and a degree of control over disclosure issues regarding their child. Once a student has turned eighteen years of age, or is “attending an institution of postsecondary education,” he or she becomes an “eligible student,” and all rights under FERPA transfer from the parent to the student (20 U.S. Code § 1232g [d]).

While FERPA is primarily known for the rights and protections it provides parents and students, the act recognizes the need for institutions of learning to use student data for quality assurance and improvement activities on the institution level; it also has provisions to facilitate external review processes for accreditation purposes, and methods by which institution personnel can distribute data acquired from research through publicly-available media in such a way that does not compromise student privacy.

Under what conditions is prior consent not required to disclose information?

34 CFR 99.31 lists all of the regulations regarding the legitimate distribution of student data *without consent*, including administrative tasks such as outsourced

¹ The FERPA statute is found at 20 U.S.C. § 1232g and the FERPA regulations are found at 34 CFR Part 99.

services (i.e. Blackboard or student data management software providers), exchange of transcripts with other institutions that the student has applied to or enrolled in, and disclosures related to financial aid applications, legal matters and health concerns. The provisions that apply to institutional research and reporting (such as a QEP) indicate that prior consent is not required if the information is:

- *Distributed to other institution officials, including teachers who have been determined to have legitimate educational interests;*
- *Distributed to an accrediting organizations to carry out their accrediting functions;*
- *De-identified—it contains no information that could disclose the identity of the student.*

Non-consent Requirements

1. Does the activity involve *legitimate educational interests*? ([34 CFR 99.31. \(1\)\(i\)\(A\)](#));

FERPA doesn't define what it means by "legitimate educational interests"; however, this provision supports the process of collecting and sharing student data among institutional personnel who are involved in the execution of a QEP for accreditation purposes. It does not, however, allow for disclosing any identifiable student information outside of the purview of those individuals directly involved with the assessment task.

NOTE: The National Center for Education Statistics notes that, while FERPA does not define "legitimate educational interests," institutions are required to have their own definitions that are distributed in annual FERPA notification letters to parents.

- For guidelines, see https://nces.ed.gov/pubs2004/privacy/section_4b.asp
- For sample definitional verbiage of "legitimate educational interests," see the Family Policy Compliance Office's "Model Notifications of Rights under FERPA for Postsecondary Institutions" go to: <http://familypolicy.ed.gov/content/model-notifications-rights-under-ferpa-postsecondary-institutions>

2. Is the data being distributed to an accrediting organization to carry out their accrediting function? ([34 CFR 99.31. \(a\)7](#));

Clearly, a QEP for SACSCOC fulfills the criteria.

3. Has the data been de-identified? ([34 CFR 99.31. \(b\)](#));

34 CFR 99.31 (b).1 states that "An educational agency or institution, or a party that has received education records or information from education records under this part, may release the records or information without the

consent required by § 99.30 after the removal of all personally identifiable information provided that the educational agency or institution or other party has made a reasonable determination that a student's identity is not personally identifiable, whether through single or multiple releases, and taking into account other reasonably available information." The provision also notes that institutions may code the records prior to de-identification in order to perform additional research (such as demographic data in a student records database) so long as:

- The method of coding the record does not allow a recipient to identify a student based on a record code;
- The record code is used for no purpose other than education research and not to determine the identity of the student;
- The record code is not based on the student's social security number or other personal information.

Obtaining Consent

34 CFR 99.30 lists all of the regulations regarding the legitimate distribution of student data that *require consent* along with specifications for what constitutes consent. For publication purposes, if the data has not been de-identified, then researchers must obtain consent from the student (and/or the parent if the student has been claimed as a dependent for tax purposes). The consent form must:

- Be dated with a written signature;
- Specify the records to be disclosed;
- State the purpose of the disclosure;
- Identify to whom the disclosure may be made.

Chart 1: Is an Activity Research Involving Human Subjects Covered by FERPA?

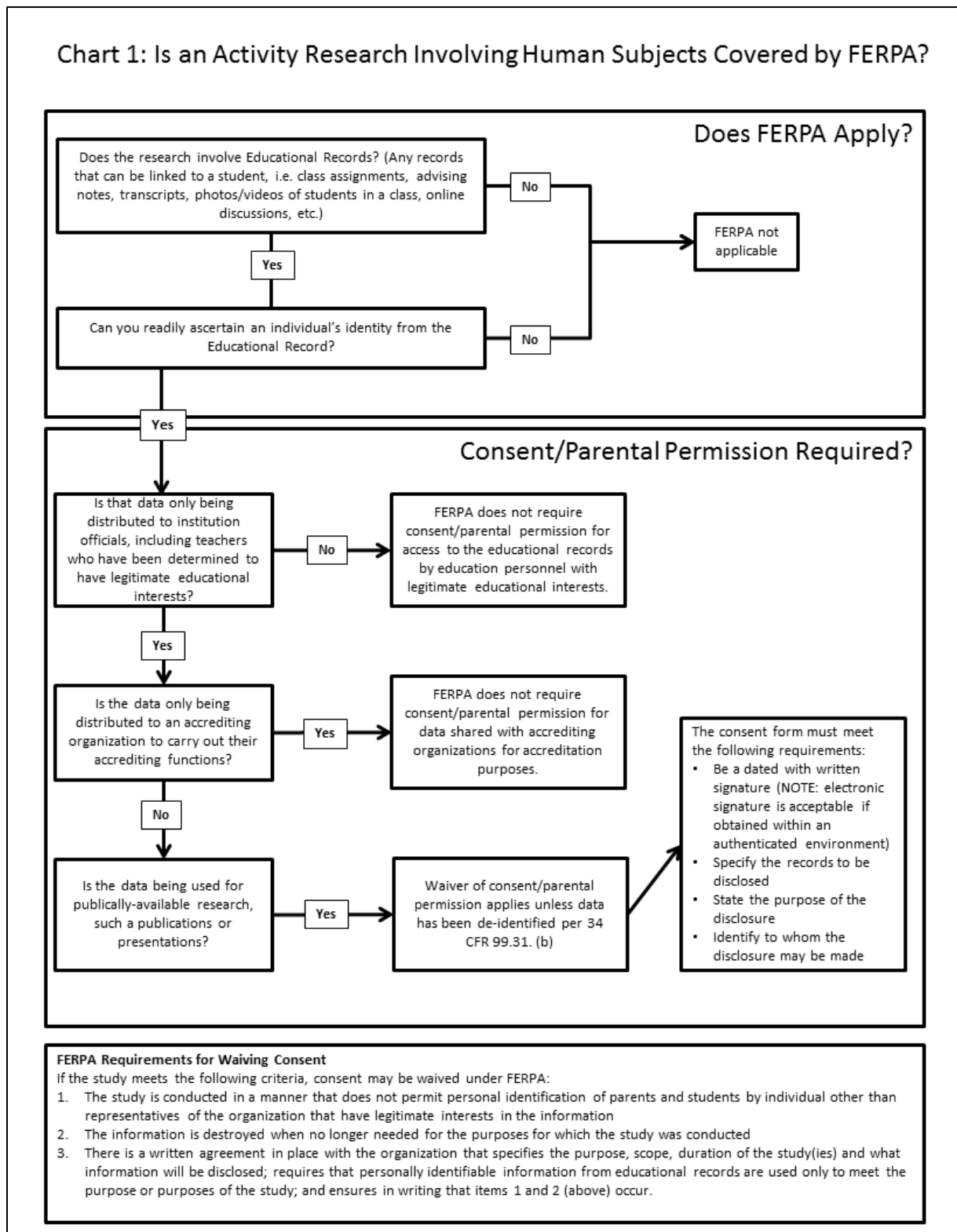

Glossary of Terms

Source (unless otherwise noted): [34 CFR 99.3 - What definitions apply to these regulations?](#)

Directory Information: the portion of the education record that would not generally be considered harmful or an invasion of privacy if disclosed. Local education agency definitions of directory information may vary, but they generally include a student's name and school activities, family members' names, address, and telephone number. Some school districts also include as directory information the biographical materials found in school yearbooks, such as videotapes and pictures of students; participation in various extracurricular activities; degrees and awards received; and names of previous schools attended. The height and weight of athletes may also be included as directory information. Once notice of directory information is given, school officials can distribute the information to anyone who requests it inside or outside the school (if parents or eligible students do not opt out). (Authority: [20 U.S.C. 1232g\(a\)\(5\)\(A\)](#))

Disclosure: to permit access to or the release, transfer, or other communication of personally identifiable information contained in education records by any means, including oral, written, or electronic means, to any party except the party identified as the party that provided or created the record. (Authority: [20 U.S.C. 1232g\(a\)\(5\)\(A\)](#))

Educational Agency or Institution: any public or private agency or institution that receives federal funding as defined under [34 CFR 99.1](#).

Education Program: any program that is principally engaged in the provision of education, including, but not limited to, early childhood education, elementary and secondary education, postsecondary education, special education, job training, career and technical education, and adult education, and any program that is administered by an educational agency or institution. (Authority: [20 U.S.C. 1232g\(a\)\(3\)](#))

Educational Record²: information directly related to a student, specifically any information recorded in any way, including but not limited to handwriting, print, computer media, videotape or audiotape, film, microfilm, and microfiche; and maintained by an education agency or institution, or by parties acting for the agency

² The source for this definition of "educational records" is "2.B. Privacy Protection Under FERPA: Responsibilities of Agencies and Schools." National Center for Education Statistics. https://nces.ed.gov/pubs2004/privacy/section_2b.asp. The CFR definition is available at <https://www.law.cornell.edu/cfr/text/34/99.3>

or institution (e.g., special education schools and health or social services institutions). Education records include but are not limited to:

- family information, such as name and address of the student and parent or guardian, emergency contact information, date and place of birth, and number of siblings;
- personal information, such as an identification code, social security number, picture, and list of personal characteristics that would make it easy to identify a student;
- grades, test scores, courses taken, academic specializations and activities, and official letters about a student's status in school;
- test records, answer sheets (including written responses to performance assessments and portfolios), and records of individualized education programs;
- special education records;
- disciplinary records established and maintained by school officials;
- medical and health records that the school collects and maintains. Individually identifiable health information of students under the age of 18 created by a nurse in a primary or secondary school that receives federal funds and that is subject to FERPA is an education record, not protected health information. Privacy regulations generally applied to health records do not apply;
- documentation of schools attended, courses taken, attendance, awards conferred, and degrees earned; and
- videotapes of individuals or groups of students.

(Authority: [20 U.S.C. 1232g\(b\)\(3\)](#), (b)(5)).

Eligible Student: a student who has reached 18 years of age or is attending an institution of postsecondary education. (Authority: [20 U.S.C. 1232g\(a\)\(4\)](#))

Institution of Postsecondary Education: an institution that provides education to students beyond the secondary school level; "secondary school level" means the educational level (not beyond grade 12) at which secondary education is provided as determined under State law. (Authority: [20 U.S.C. 1232g\(d\)](#))

Personally Identifiable Information: includes, but is not limited to the student's name; the name of the student's parent or other family members; the address of the student or student's family; a personal identifier, such as the student's social security number, student number, or biometric record; other indirect identifiers, such as the student's date of birth, place of birth, and mother's maiden name; other information that, alone or in combination, is linked or linkable to a specific student that would allow a reasonable person in the school community, who does not have personal knowledge of the relevant circumstances, to identify the student with

Ratliff and Baker
QEP, IRB, FERPA, and SACS-COC

Atlanta, Dec 2016

reasonable certainty; or information requested by a person who the educational agency or institution reasonably believes knows the identity of the student to whom the education record relates. (Authority: [20 U.S.C. 1232g\(b\)\(4\)\(A\)](#))