

# GRAPHIC DESIGN PROGRAM UNIVERSITY OF THE INCARNATE WORD

## BFA PORTFOLIO REVIEW

The aim of the Graphic Design program is to prepare students for a demanding and competitive profession. Dedication to this goal means that the program must be selective in quantity in order to offer the best quality opportunity that we can.

Because the Graphic Design program requires a specific set of skills, all students planning on entering the Graphic Design Program must submit a portfolio for review in order to be admitted.

Portfolios will be reviewed at the end of the Foundations year. Transfer students who wish to start in the program classes must submit a portfolio at the scheduled portfolio review time the SPRING semester before they plan to attend.

*Each year, a limited number of students will be admitted to the program level. Only those passing the review will be allowed to register for GDSN courses.*

*Since the number of applicants will vary each year, passing grades in Foundations year classes will not guarantee admission.*

Students who do not pass the portfolio review may resubmit a portfolio the following year. It is strongly recommended that you retake some or all of your GDSN foundations classes to enhance your skills before resubmitting your portfolio.

## WHAT GOES INTO YOUR PORTFOLIO:

1. Projects from the following courses:

- GDSN 1301 – Graphic Design Software
- GDSN 1380 – Foundations of Design
- GDSN 1215 – Digital Imaging
- GDSN 1210 – Drawing for Designers
- GDSN 1390 – Typography I

2. A selection of 3--- 5 pieces from

- ARTS 1301 – Drawing I

3. A current (unofficial) transcript

The primary criteria used in making selections for admission into the graphic design program will be the work presented in the portfolio from GDSN 1301, 1210, 1215, 1380, & 1390.

## PORTFOLIOS WILL BE EVALUATED ON HOW WELL EACH STUDENT HAS DEMONSTRATED:

### Understanding of Design and Aesthetics

- visual organization, composition
- understanding of color, value, and texture
- attention to detail
- understanding of and application of design principles

### Visual problem solving

- creativity, imaginative thinking
- range and variety of ideas
- development and improvement of concept

### Skills

- craft and hand skills
- drawing, observation
- technical skill with tools, materials
- quality of execution, care for the appropriate presentation of your work
- understanding of software

### Work ethic / Participation / Behavior

- consistent performance as reflected in class preparation
- participation and interest in your own work and that of others
- shows respect towards the instructor and their classmates
- ability to stay on task and use class time wisely

### Overall quality of visual presentation Critical analysis and research skills

## PRESENTATION & DEADLINES

All work must be submitted in portfolio case with your name on the outside of the portfolio.

Portfolios should be turned in to the office of the Program Coordinator for Graphic Design (AD 409) between the hours of 9 AM—4 PM, Monday, May 6<sup>th</sup> through Thursday, May 9<sup>th</sup>.

All portfolios must be complete and turned in by 4 PM, Thursday, May 9<sup>th</sup> in to be considered for review this year.

You may pick up your portfolio the following Monday, May 13<sup>th</sup>, 2019, in the same location.

There will be an evaluation sheet placed in each portfolio. This sheet will have a 0---4 “ranking” on each of the evaluation criteria and will inform you whether or not you have been admitted to the Graphic Design major and cleared to take program level courses. A letter of confirmation will follow.

*Transfer Students Only:* Two additional dates have been set for Transfer Student Portfolio Reviews. These dates are Friday, June 21<sup>st</sup>, and Friday, August 9<sup>th</sup>. For more information about this review, please contact Professor Clayton at [clayton@uiwtx.edu](mailto:clayton@uiwtx.edu) or (210) 805-1212.

**GRAPHIC DESIGN PROGRAM UNIVERSITY OF  
THE INCARNATE WORD**

**PORTFOLIO REVIEW APPLICATION**

Name: \_\_\_\_\_

PIDM: \_\_\_\_\_

Email: \_\_\_\_\_

Phone: \_\_\_\_\_

<input type="checkbox"/> Admitted to the Graphic Design Program	<input type="checkbox"/> Not admitted to the Graphic Design Program.
<input type="checkbox"/> Conditionally admitted to the Graphic Design Program	

**Portfolio Evaluation:** This evaluation is provided to assist students in understanding their individual strengths and weaknesses. 4 is the highest rating in each category.

**Understanding of Design and Aesthetics**

visual organization, composition	0	1	2	3	4
understanding of color, value, and texture	0	1	2	3	4
attention to detail	0	1	2	3	4
understanding of and application of design principles	0	1	2	3	4

**Visual problem solving**

creativity, imaginative thinking	0	1	2	3	4
range and variety of ideas	0	1	2	3	4
development and improvement of concept	0	1	2	3	4

**Skills**

craft and hand skills	0	1	2	3	4
drawing, observation	0	1	2	3	4
technical skill with tools, materials	0	1	2	3	4
quality of execution, appropriate presentation of your work	0	1	2	3	4
understanding of software	0	1	2	3	4

**Work ethic / Participation / Behavior**

consistent performance as reflected in class preparation	0	1	2	3	4	n/a
participation and interest in your own work and that of others	0	1	2	3	4	n/a
shows respect towards the instructor and their classmates	0	1	2	3	4	n/a
ability to stay on task and use class time wisely	0	1	2	3	4	n/a

**Overall quality of presentation**

Overall quality of presentation	0	1	2	3	4
---------------------------------	---	---	---	---	---

**Critical analysis and research skills**

Critical analysis and research skills	0	1	2	3	4	n/a
---------------------------------------	---	---	---	---	---	-----

*\* n/a is used in evaluating portfolios submitted from transfer student applicants in which this information is not available*

# Portfolio Case

Mounted Boards from:

- Foundations of Design
- Graphic Design Software
- Digital Imaging\*
- Typography I\*

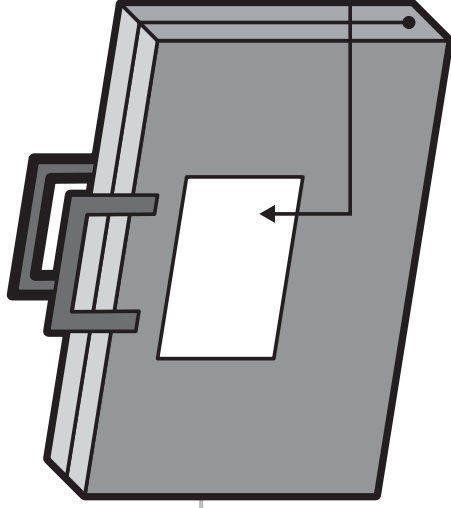

# Reusable Bag

Binders, Envelopes, and Portfolio Book from:

- Foundations of Design
- Graphic Design Software & Digital Imaging
- Typography I\*
- Drawing for Designers\*

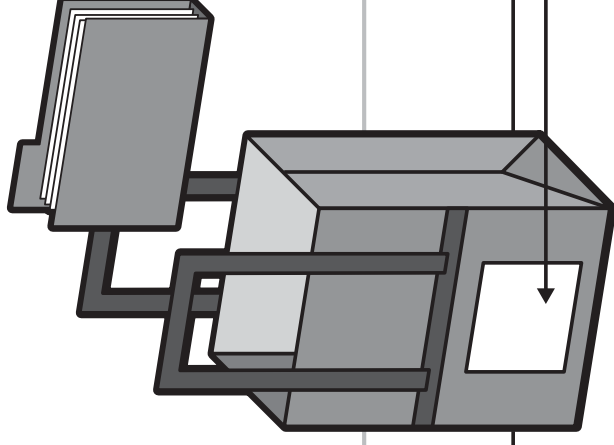

# Folder

Please include:

- Portfolio Review Application
- Current Transcript (Unofficial is okay)

# Tube

Large format work from:

- Drawing I
- Digital Imaging



Please label all of the items that you are submitting for the review.

*\* Work from these classes that was turned in at the end of the semester will be added to your portfolio by the faculty prior to the review.*